



# 安装说明 / INSTALLATION INSTRUCTIONS

## H系列纸卷夹 H-Series Roll Clamps



官方微信号 天猫旗舰店



服务热线

Customer Service Hotline

40088 57315

# 目录 CONTENTS

介绍	INTRODUCTION	i
特别定义	SPECIAL DEFINITIONS	1
推荐供油系统	RECOMMENDED HYDRAULIC SUPPLY	2
安装前对叉车的要求	TRUCK REQUIRMENTS	3
安装	INSTALLATION	4
定期维护保养	PERIODIC MAITENANCE	5

▲ **警告：** 安装不当是导致属具故障的第一要素，请在安装属具前认真阅读本《安装说明书》。

▲ **注意：** 叉车/属具组合承载能力系由叉车主机厂确定，其值可能比属具铭牌上所示数值小，请参见叉车铭牌。

💡 **重要提示：** 现场改动将减弱属具的性能和承载能力，并导致失去保修资格。任何需要对属具进行的改动，请事先与卡斯卡特公司协商。

▲ **WARNING:** Incorrect installation is the main cause of Attachment malfunctioning. Please read this **INSTALLATION INSTRUCTION** comprehensively before installation.

▲ **CAUTION:** Rated capacity of the truck/attachment combination is a responsibility of the original truck manufacturer and may be less than shown on the attachment name plate. Consult the truck nameplate.

💡 **IMPORTANT:** Field alterations may impair performance or capability and could result in loss of warranty. Consult Cascade for any required modifications. Operating at pressures over 160bar(2300 psi) will void warranty.

# 介绍 / INTRODUCTION

本手册为卡斯卡特H系列固定框架式纸卷夹提供了安装说明和定期维护保养。

关于纸卷夹的任何信息都要追溯到铭牌上的产品编号。如果铭牌丢失，则可以在面板的顶部或侧面找到刻在上面的产品编号。

**重要提示：** H系列纸卷夹上的软管，钢管以及接头都符合JIC标准。

**注意：** 所有的参数都有英制和公制两种。

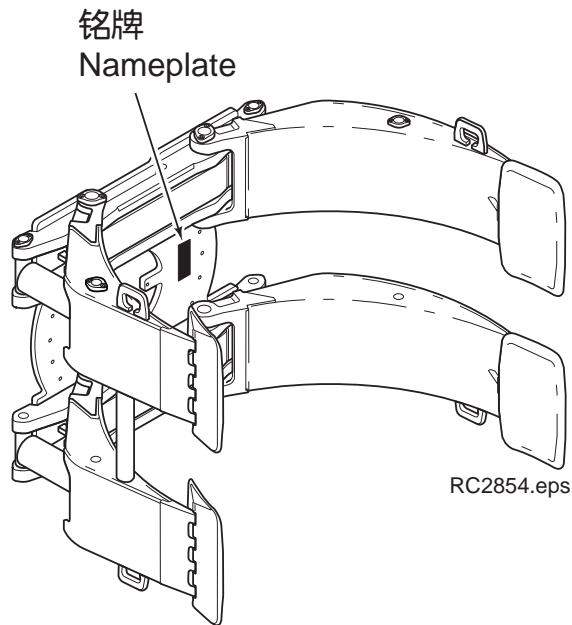

This manual provides installation instructions and periodic maintenance for Cascade H-Series Fixed Frame Paper Roll Clamps.

In any communication about the Roll Clamp refer to the product I.D. number stamped on the nameplate. If the nameplate is missing, the numbers can be found stamped on the front of the faceplate top or side.

**IMPORTANT:** All hoses, tubes and fittings on H-Series Roll Clamps are JIC.

**NOTE:** Specifications are shown in both U.S. and (Metric) units.

新铭牌 New Nameplate

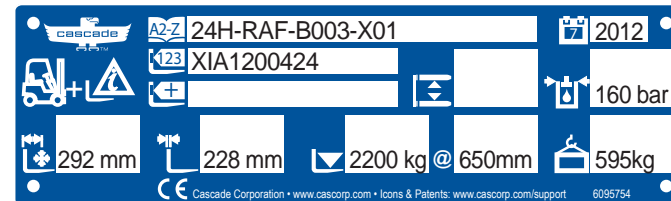

旧铭牌 Old Nameplate

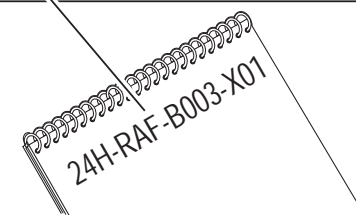
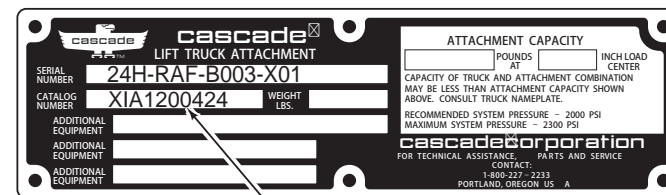

# 特别定义

# SPECIAL DEFINITIONS

本手册含有一些特别提示，操作前务必仔细阅读所有的“警告”和“注意”。“重要提示”和“备注”则作为具有特定意义或简化工作的信息提供。



**警告：** 所示内容必须切实牢记，以免造成人身伤害。警告说明始终位于一个制定的方框内。

**注意：** 此类标识的内容必须遵守，以免造成设备损坏。

**重要提示：** 这种提示包含特定信息。

**备注：** 这种标识所含信息便于简化您的工作。

The statements shown below appear throughout this manual where special emphasis is required. Read all **WARNINGS** and **CAUTIONS** before proceeding with any work. Statements labeled **IMPORTANT** and **NOTE** are special information that is useful when servicing the attachment.



**WARNING** - A statement preceded by a **WARNING** is information that should be acted upon to prevent **bodily injury**. A **WARNING** is always inside a ruled box.

**CAUTION** - A statement preceded by **CAUTION** is information that should be acted upon to prevent machine damage.

**IMPORTANT** - A statement preceded by **IMPORTANT** is information that possesses special significance.

**NOTE** - A statement preceded by **NOTE** is information that is handy to know and may make the job easier.

# 对叉车的要求

# T RUCK REQUIRMENTS



警告：叉车/属具的中和承载能力有叉车制造商决定，它可能比属具铭牌所标注的数值来得低。

**WARNING:** Rated capacity of the truck/attachment combination is a responsibility of the original truck manufacturer and may be less than that shown on the attachment nameplate. Consult the truck nameplate.

## 多路阀功能

按照ANSI(ISO)的标准检查下列功能：

### Auxiliary Valve Functions:

Check for compliance with ANSI(ISO) standards

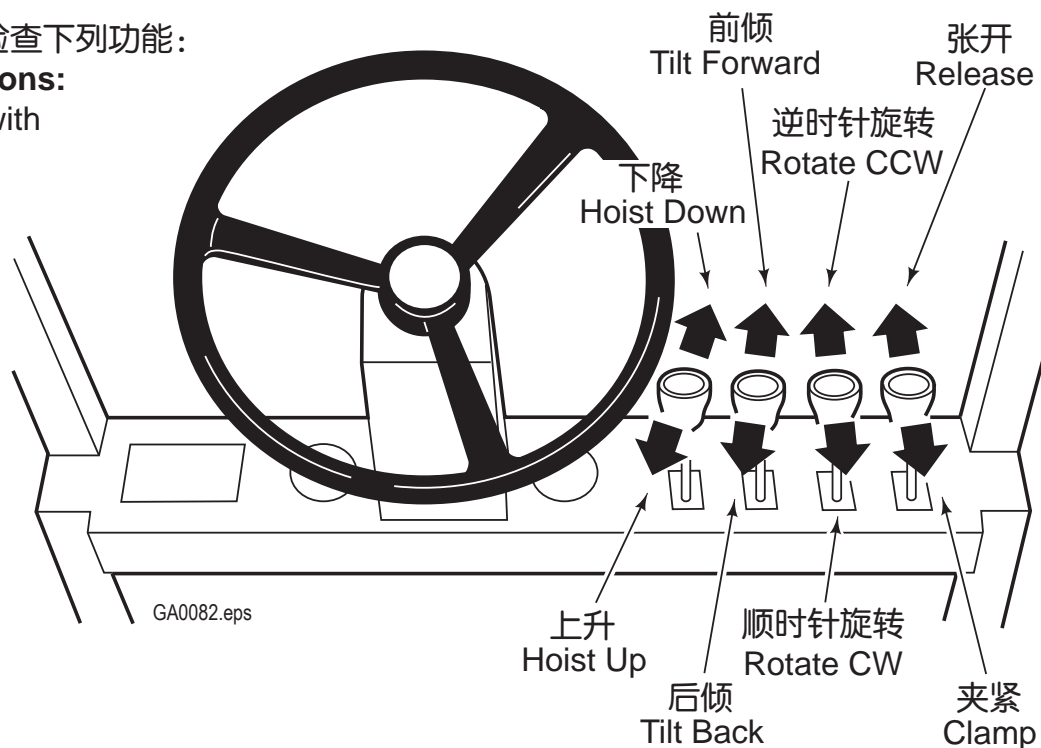

# 对叉车的要求

# T RUCK REQUIREMENTS

叉车供油压力Truck Relief Setting  
 最大值(Maximum Pressure):160bar(2300psi)

叉车供油流量Truck Flow Volume<sup>①</sup>

	最小值Min <sup>②</sup>	推荐值Recommended	最大值Max <sup>③</sup>
13H	19L/min (5GPM)	26L/min (7GPM)	38L/min (10GPM)
(18H)	19L/min (5GPM)	32L/min (8.5GPM)	45L/min (12GPM)
24H, X24H, 30H (20H, 22H, 25H, 33H)	19L/min (5GPM)	38L/min (10GPM)	57L/min (15GPM)

①卡斯卡特纸卷夹兼容SAE10W的油基液压油标准参见MIL.Spec规格MIL-0-5606或者MIL-0-2104B.不推荐使用合成或水基液压油.如果需要使用阻燃液压油,则必须采用特殊密封件.详细请联系卡斯卡特.

②如果流量低于推荐值,会造成纸卷夹的转速低于2转/分.

③如果流量超过最大值,会造成过热,降低系统性能同时缩短液压系统的寿命.

①Cascade Roll Clamps are compatible with SAE 10W petroleum base hydraulic fluid meeting Mil.Spec.MIL-0-5606 or MIL-0-2104B. Use of synthetic or aqueous base hydraulic fluid is not recommended.If fire resistant hydraulic fluid is required,special seals may be required. Contact Cascade.

②Flow less than recommended will result in excessive a rotate speed less than 2 RPM.

③Flow greater than maximum can result in excessive heating, reduced system performanceand reduced hydraulic system life.

## 货叉架

清理并检测货叉架的横梁的破损和光滑度。修补所有被破损的凹坑。

## Carriage

Clean and inspect carriage bars for damage and smoothness. Repair any protruding welds or damaged notches.

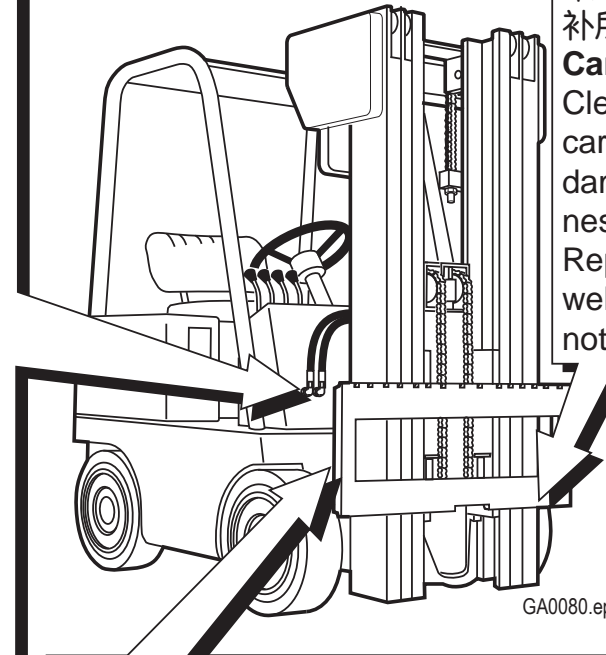

货叉架安装尺寸(A)ITA (ISO)  
 Carriage Mount Dimension(A) ITA (ISO)

	最小值Min	最大值Max
Class II	380.0 mm(14.94in.)	381.0 mm(15.00in.)
Class III	474.5 mm(18.68in.)	476.0mm(18.74 in.)
Class IV	595.5 mm(23.44in.)	597.0 mm(23.50in.)



# 推荐供油系统

# RECOMMENDED HYDRAULIC SUPPLY

H系列纸卷夹出色的供油系统如下所示。参考卡斯卡特卷管器和带电缆卷管器的选用指南，编码212199，它用于指导正确为门架和叉车选择卷管器，软管和接头要求如下：

●推荐软管和管接头规格：

a. 夹持油路

所有型号 - #6管接头， 通径 $\geq 7\text{mm}$ 。

b. 旋转油路

13H（及18H） - #6管接头， 通径 $\geq 7\text{mm}$ 。

24H, X24H, 30H（及20H, 22H, 25H, 33H等） - #8管接头， 通径 $\geq \phi 10\text{mm}$ 。

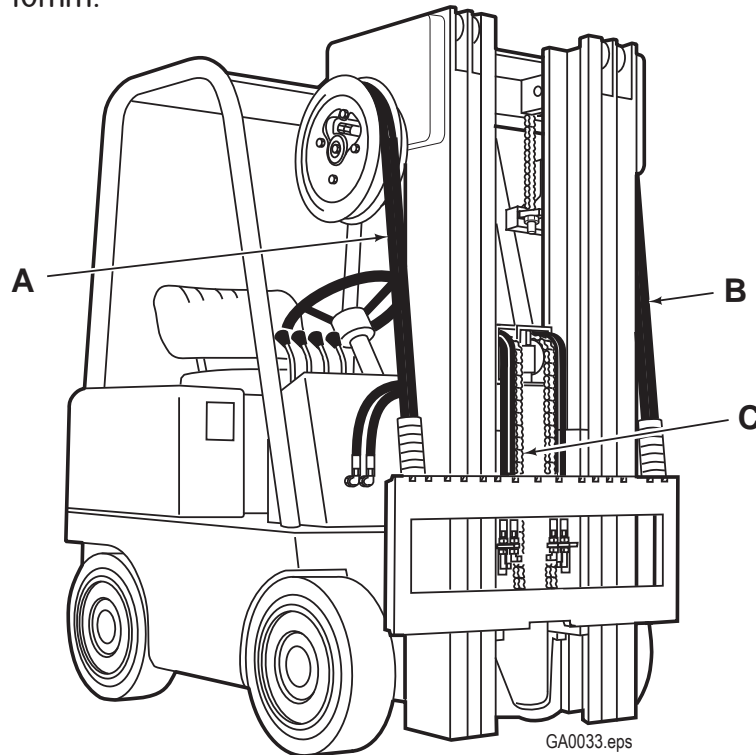

H-Series Fixed Frame Paper Roll Clamps provide the best performance with the hydraulic supply arrangement shown below. Refer to Cascade Hose and Cable Reel Selection Guide, Part No. 212119, to select the correct hose reel for the mast and truck. The hose and fitting requirements are:

●Recommended hose and fitting size:

a. Clamp

All model — All hoses and fittings for clamp function require No. 6 hose with 7mm minimum ID.

b. Rotate

13H (and 18H) — All hoses and fittings for clamp function require No. 6 hose with 7mm minimum ID.

24H, X24H, 30H (and 20H, 22H, 25H, 33H etc.) — All hoses and fittings for clamp function require No.8 hose with 10mm minimum ID.

A和B 右侧两管式细管卷管器

或

A和C 内系油路

**A and B**

RH and LH THINLINE™ 2-Port Hose Reel Groups.

**OR**

**A and C**

RH THINLINE™ 2-Port Hose Reel Group and Mast Single Internal Hose Reeving Group.



# 安装

# INSTALLATION

按以下的步骤将属具安装到叉车上。仔细阅读并理解所有警告和注意，如果您有任何不理解的程序，请向您的主管或就近的卡斯卡特服务部门询问。

Follow the steps shown to install the attachment on the truck. Read and understand all WARNINGS statements. If a procedure is not understood, ask a supervisor or call the nearest Cascade Service Department for assistance.

## 1 起吊属具

A 把属具翻转到朝上的位置。

B 拆下下钩螺栓。

### Attach overhead hoist

A Remove banding, set attachment upright on pallet.

B Remove bolt-on lower mounting hooks if equipped.

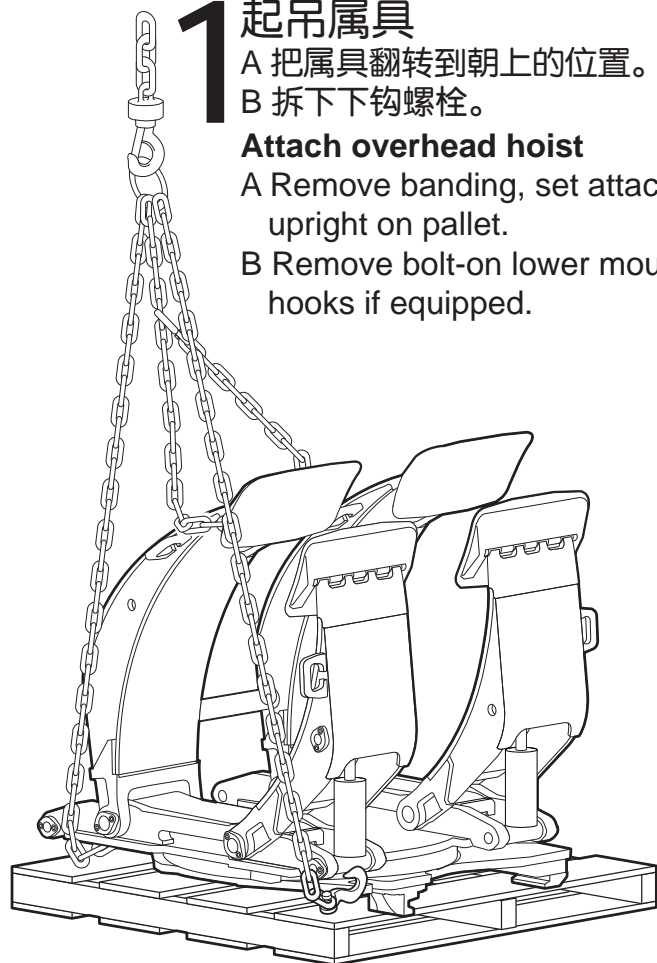

**警告：** 核实起吊设备，链条或绳索的额定承载能力不低于属具自重。请查阅铭牌上的属具自重。

**WARNING:** Verify that the overhead hoist and chains or straps are rated for the weight of the attachment. Refer to nameplate for attachment weight.

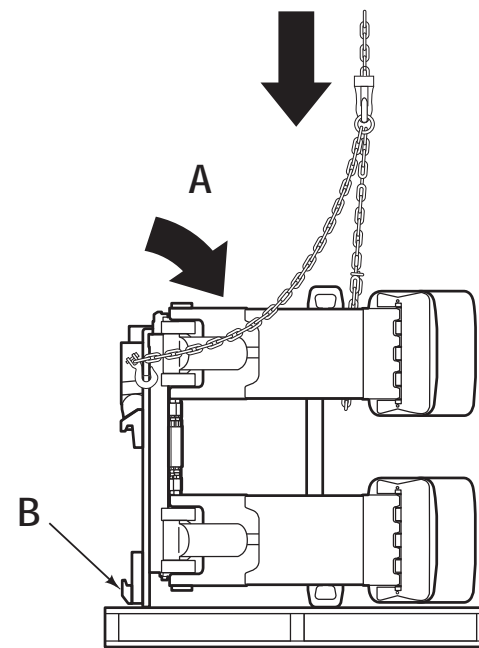
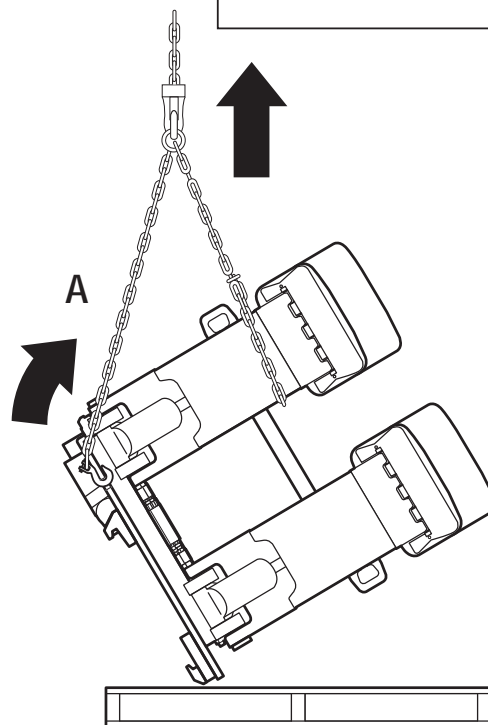

RC2842.eps



## 2

### 拆下快换式下钩

A 将下钩移到松开的位置。

B 重新将销轴插入下钩的插孔中。

### Unlock Quick-Change lower mounting hooks

A Move hooks into unlocked position

B Reinstall pin in lower hole

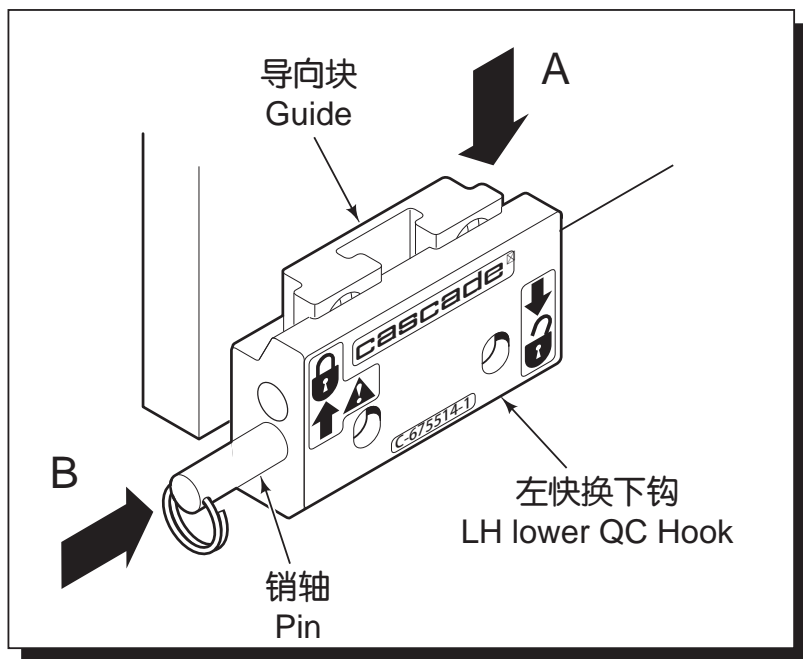

注意：导向块可以翻转过来以改变下钩和货叉架之间的间隙（参见步骤7）

Note: Guides can be reserved to change hook-to-carriage clearance(See Step 7).

导向块顶部有16mm的偏移值，可产生最大的间隙。

16mm(5/8-in.) offset on top provides maximum clearance.

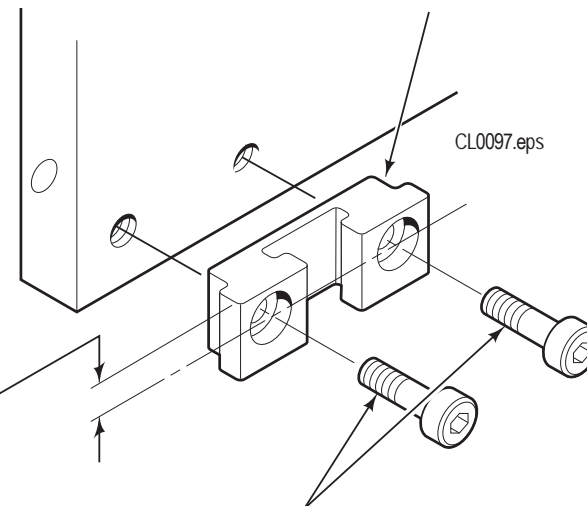

用165Nm的力矩锁紧螺栓。

Tighten capscrews to 125 ft.-lbs.(165Nm)

## 3 准备管路

- A 对位好属具后面的叉车货叉架。
- B 按要求选择软管长度。
- C 切除软管的多余长度，扣压上管接头。

**警告：** 如果旋转油路产生的背压超过35bar，将造成油温过热，降低属具性能并缩短液压系统的寿命。检查一些设定诸如众多管接头，管接头/软管的规格尺寸#6（13H及18H），#8（24H,X24H,30H及20H,22H,25H,33H等）是否满足要求。

**警告：** 若按照#6软管（13H及18H），#8软管（24H,X-24H,30H及20H,22H,25H,33H等）以及160bar的最大工作压力来配置，可满足所有功能需求。

## Preparing Hoses

- A Position truck carriage behind attachment.
- B Determine hose lengths required.
- C Cut hoses to length, install end fittings.

**CAUTION:** Rotate function supply circuit back pressure exceeding 35 bar (500 psi ) can result in excessive oil heating, reduced attachment performance and shortened hydraulic system life. Check for restrictions such as numerous fittings and fitting/hose sizes less than No. 6 (13H and 18H) or No. 8. (24H, X24H, 30H and 20H, 22H, 25H, 33H etc.).

**CAUTION:** Use No. 6 Hoses (13H and 18H) and No. 8 Hoses (24H, X24H, 30H and 20H, 22H, 25H, 33H etc.), 160 bar (2300 psi) maximum working pressure for all functions.

采用2个细管卷管器(左侧+右侧),两管式

### INSTALLATION USING RH & LH 2-PORT THINLINE™ HOSE REELS:

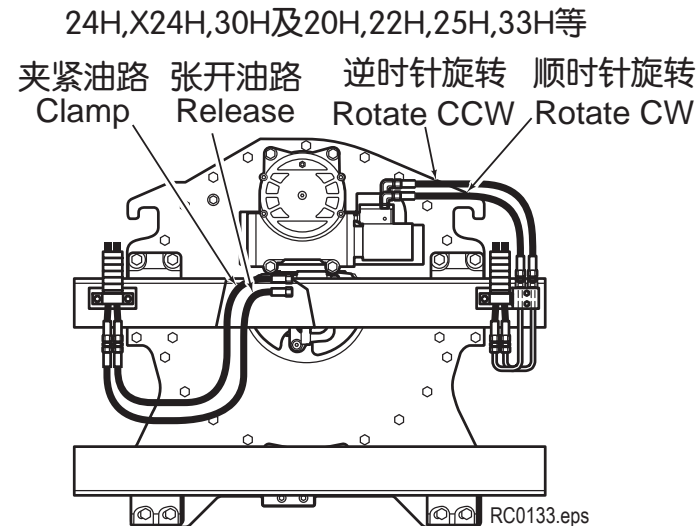
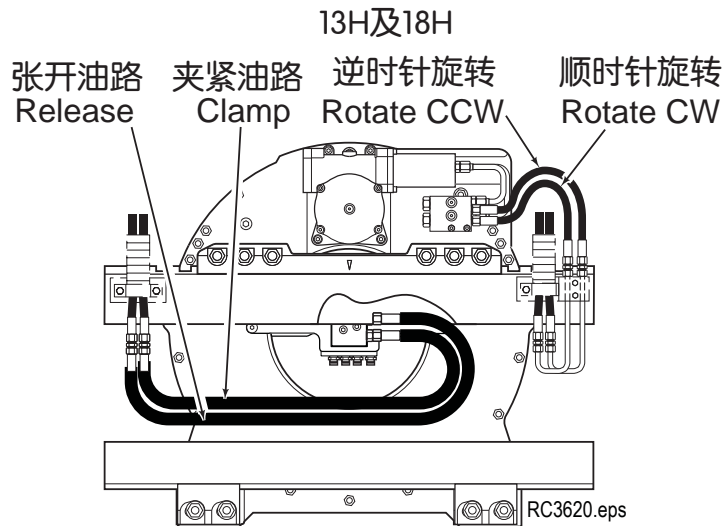

## 4

冲洗油管

A 按图示安装油管。

B 操作多路阀30秒。

C 拆下接头。

Flush hydraulic supply hoses

A Install hoses as shown.

B Operate auxiliary valves for 30 sec.

C Remove union fittings.

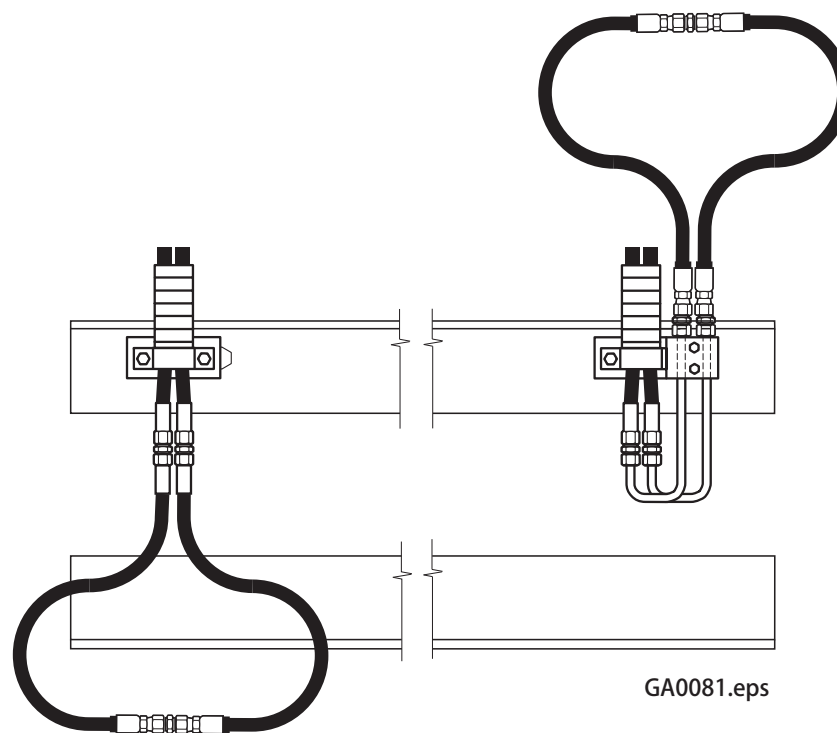

## 5

取下减速箱体端盖堵头，检查油位。  
Remove gearbox end cover fitting, check lubricant level.

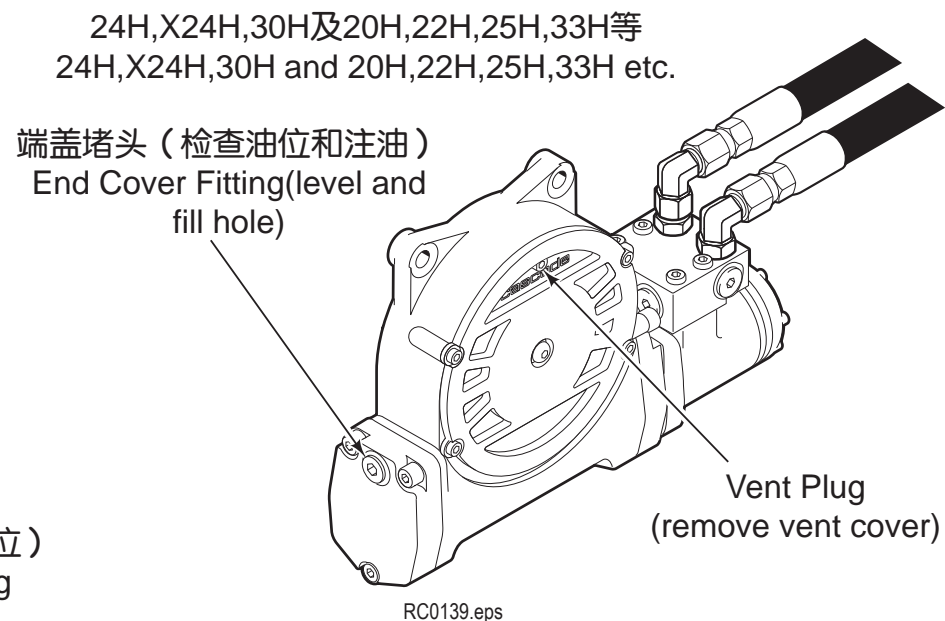
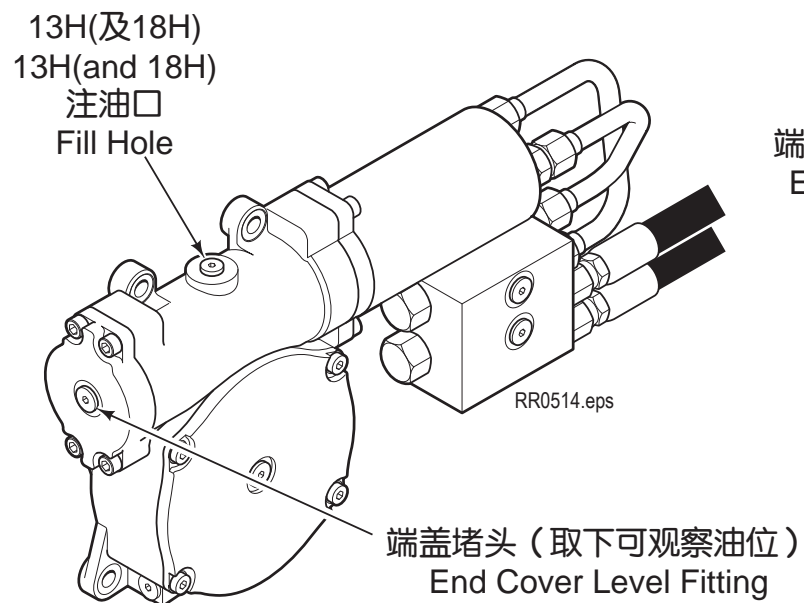

需要的话，注入卡斯卡特齿轮润滑油656300或同等的SAE90 wt润滑油（AGMA“中性”6EP齿轮油）。  
If necessary, fill gearbox with Cascade Gear Lube 656300 or equivalent SAE 90 wt. gear lube(AGMA "mild" 6EP oil).

## 6

将纸卷夹挂装到叉车货叉架上

A 将叉车从属具背后对中。

B 将门架倾斜并上升货叉架到合适的位置。

C 将上钩挂装到货叉架上横梁上。

13H,18H (ISO II级), 25H-33H (ISO III级) -确保中央固定块可嵌入货叉架上横梁的中间槽口。

20H-24H (ISO II级/III级), 25H-33H (ISO III级/IV级) -确保左上钩上的挡块嵌入到货叉架上横梁的槽口内。

D 将纸卷夹提升至距托盘5cm的高度。如果需要的话, 确保中央垫块能嵌入到下横梁中。

中央固定块 (图示为13H上钩, 标注处为中央固定块)  
Centering Tab(13H upper hook shown)

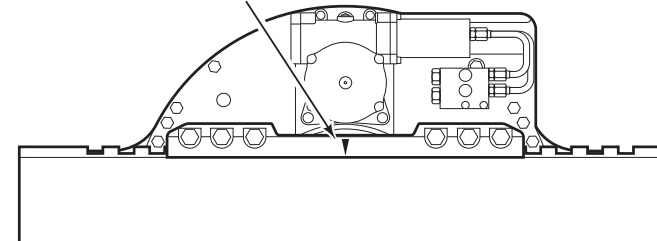

Mount attachment on truck carriage

A Center truck behind attachment.

B Tilt forward and raise carriage into position.

C Engage top mounting hooks with carriage.

13H,18H(CL II),25H-33H(CL III), Make sure the centering tab engages the center notch on top carriage bar.

X24H,20H-24H(CL II/III),25H-33H(CL II/IV)-Make sure left hook engages closet notch on top carriage bar.

D Lift attachment 5 cm(2 in.)off pallet.Make sure lower index block(if equipped) engages fork slot on lower carriage bar.

## 6

ISO II级—15-17mm

ISO III级—18-20mm

ISO IV级—18-20mm

ITA Class II – 15–17 mm (0.60–0.66 in.)

ITA Class III – 18–20 mm (0.72–0.78 in.)

ITA Class IV – 18–20 mm (0.72–0.78 in.)

ISO II级—8-9mm

ISO III级—10-11mm

ISO IV级—12-13mm

ITA Class II – 8–9 mm (0.32–0.36 in.)

ITA Class III – 10–11 mm (0.39–0.43 in.)

ITA Class IV – 12–13 mm (0.47–0.51 in.)

槽  
Notch

II / III 级挂装的货叉架上  
横梁和上钩如图示。  
Class II/III carriage  
bars and upper  
mounting hooks shown.

货叉架上横梁  
Upper Carriage Bar

GA0079.eps

软管与旋转油口相连接  
Hoses are connected to  
Revolving Connection

中间垫块  
Index Block or Spacer Block

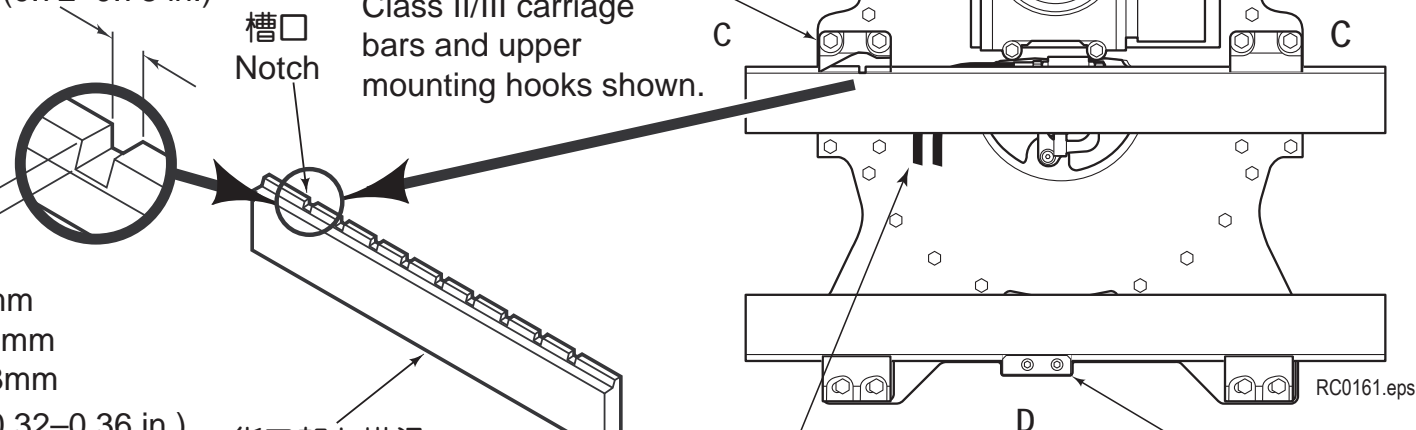

RC0161.eps

## 7

安装并嵌入下钩

Install and engage lower hooks

螺栓紧固式  
BOLT-ON TYPE

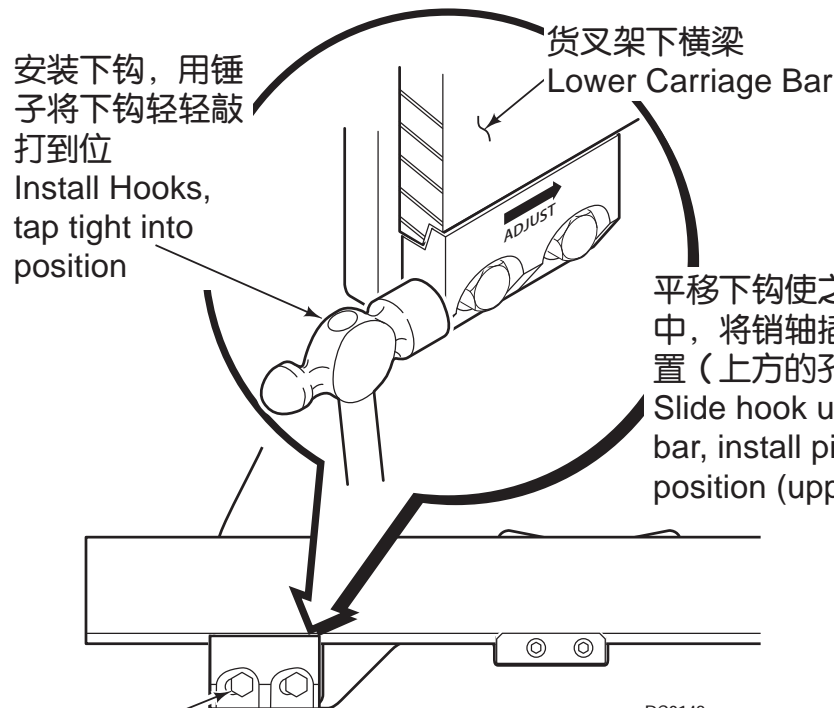

安装下钩，用锤子将下钩轻轻敲打到位  
Install Hooks, tap tight into position

平移下钩使之嵌入下横梁中，将销轴插入锁紧的位置（上方的孔）  
Slide hook up to engage bar, install pin in locked position (upper hole)

螺栓锁紧扭矩：  
ISO II级/III级—165Nm  
ISO IV级—320Nm

Tighten capscrews to:  
Class II/III-165Nm(125ft.-lbs.)  
Class IV-320Nm(235ft.-lbs.)

RC0148.eps

快装型（可选项）  
QUICK-CHANGE TYPE(OPTIONAL)

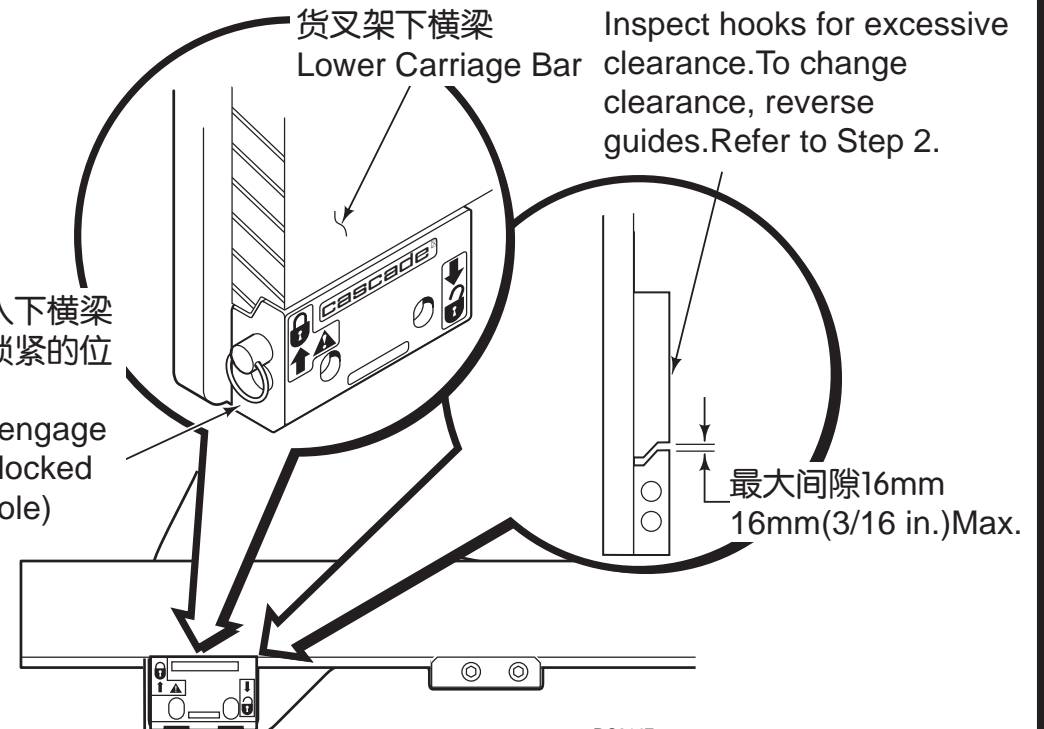

检测下钩的过渡间隙。翻转导向块以改变间隙，参见步骤2。

Inspect hooks for excessive clearance. To change clearance, reverse guides. Refer to Step 2.

最大间隙16mm  
16mm(3/16 in.)Max.

RC0147.eps



## 8

将油管与接头相连接

Connect hoses to hose terminal fittings

采用2个细管卷管器（左侧+右侧），两管式  
INSTALLATION USING RH & LH 2-PORT THINLINE™ HOSE REELS

13H(及18H)  
13H(and 18H)

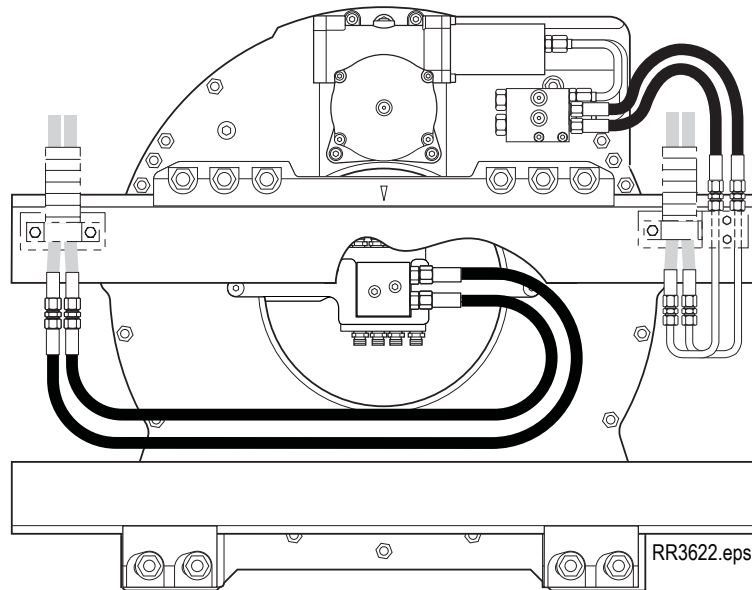

24H,X24H,30H及20H,22H,25H,33H等  
24H,X24H,30H and 20H,22H,25H,33H etc.

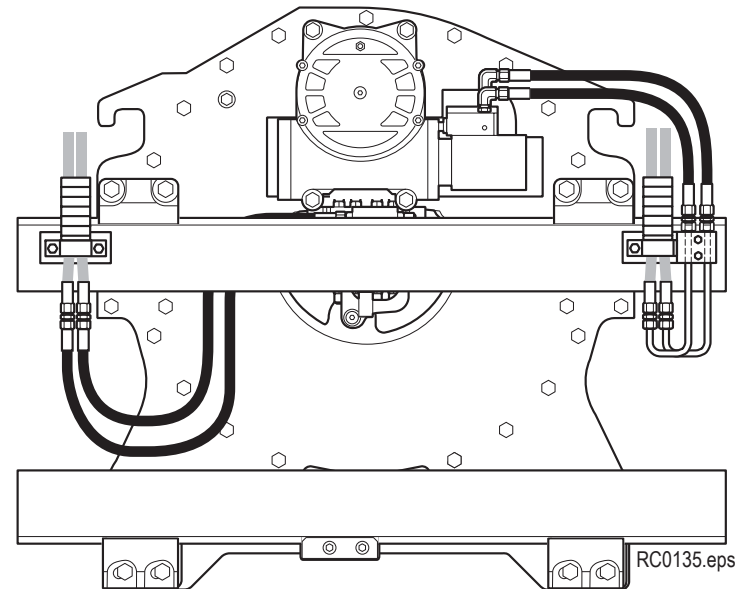

叉车驾驶员角度  
Back (Driver's) Views

## 9 安装止动块

- 在每一个上钩外侧安放一个止动块。每个止动块和上横梁焊接区域应预热到180℃。
- 使用AWS E7018号低氢焊条，如图对止动块进行三面填充焊接，焊缝高度为6mm。

24H,X24H,30H及20H,22H,25H,33H等  
24H,X24H,30H and 20H,22H,25H,33H etc.

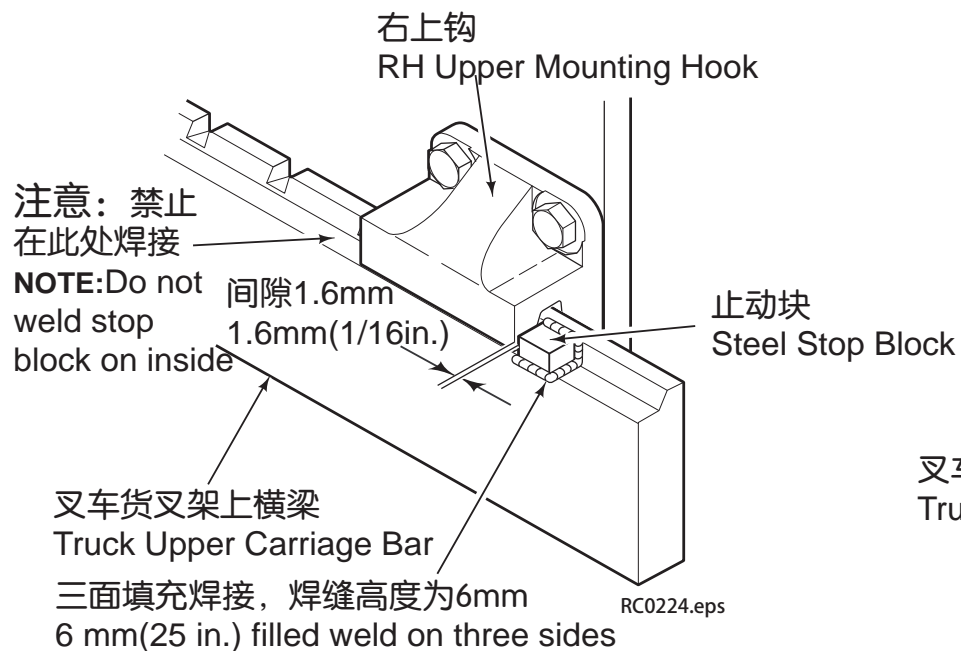

## Install stop block kit

- Locate one stop block on the outside of each upper hook. Preheat each stop block and carriage bar weld area to 325 °F (180 °C).
- Use AWS E7018 low hydrogen rod and weld a 6 mm (.25 in.) fillet full length

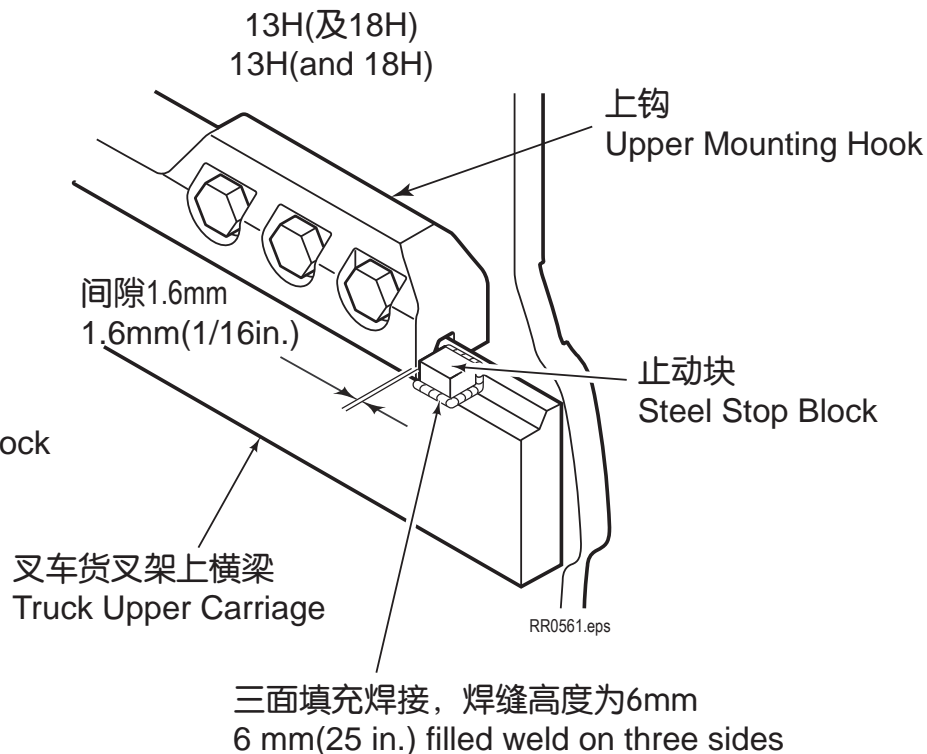

## 10

如需要可加装180°旋转止动阀  
Adjust 180° stop valve(if equipped/required)



**警告：** 在调整期间，确保所有人员对属具都很熟悉。  
**WARNING:** Make sure all personnel are clear of attachment during adjustment.

**A** 带一个调节螺栓的阀体—松开旋转止动阀上的锁紧螺母，用螺丝刀将螺栓旋进（沿顺时针方向）直到顶死。反向旋转一圈。

带两个调节螺栓的阀体—松开旋转止动阀上的锁紧螺母，用螺丝刀将螺栓旋出（沿逆时针方向）直到螺栓伸长到极限位置。两个可调螺栓应等量调整。

**重要说明：** 方向旋出螺栓将造成液压泄露。

**B** 添加负载：A)选用最重的负载，或者B)在用调节前，用马达最大的扭矩，在两个挡块之间以最快的速度来回旋转属具1-2分钟。观察属具是否能够缓慢地旋转并碰到挡块。

**C** 如果旋转过程不能连续碰到挡块，则扭转止动阀并将其从斜面（如图示）上卸下，并进行调整将螺栓旋进（沿顺时针方向）1/8圈。检测是否能够缓慢地旋转并碰到挡块。

**D** 重复步骤C直到属具完全实现缓慢旋转并急停。锁紧位于调整螺栓上的锁紧螺母。

**E** 核实挡块上螺栓的扭矩，如果需要，用110Nm的扭矩锁紧。

**A** Valves with One Adjustment Screw – Loosen the jam nut on the stop valve adjustment screw and turn the screw IN (clockwise) until it stops. Back out one turn.

Valves with Two Adjustment Screws – Loosen the jam nut on the stop valve adjustment screws and turn the screws OUT (counterclockwise) until a groove marking the maximum-out position is visible. Adjustment screws should be adjusted equally.

**IMPORTANT:** Backing the adjustment screws out past the groove will cause hydraulic leakage.

**B** Using a load that: A) is the heaviest to be lifted, or B) requires maximum motor torque, rotate the attachment back and forth to the stops at full speed for 1–2 minutes before making adjustments. Observe whether the attachment fully completes its rotation slowly into the hard stop.

**C** If rotation does not continue into the hard stop, rotate the stop valve off the ramp and turn the adjustment screw IN (clockwise) one-eighth turn. Test for complete rotation slowly into the hard stop.

**D** Repeat Step C until the attachment fully completes its rotation slowly into the hard stop. Tighten the jam nut on the adjustment screw.

**E** Check the torque on the stop block capscrews and tighten to 80 ft.-lbs. (110 Nm), if necessary.

# 10

带一个调节螺栓的阀体  
Valve with one Adjustment Screw

180° 旋转止动阀  
180° Stop Valve

E  
挡块  
Stop Block

C  
斜面  
Ramp

A  
可调螺栓和锁紧螺母  
Adjustment Screw and Jam Nut

可调螺栓和锁紧螺母  
Adjustment Screw and Jam Nut

斜面  
Ramp

带两个调节螺栓的阀体  
Valve with two Adjustment Screws

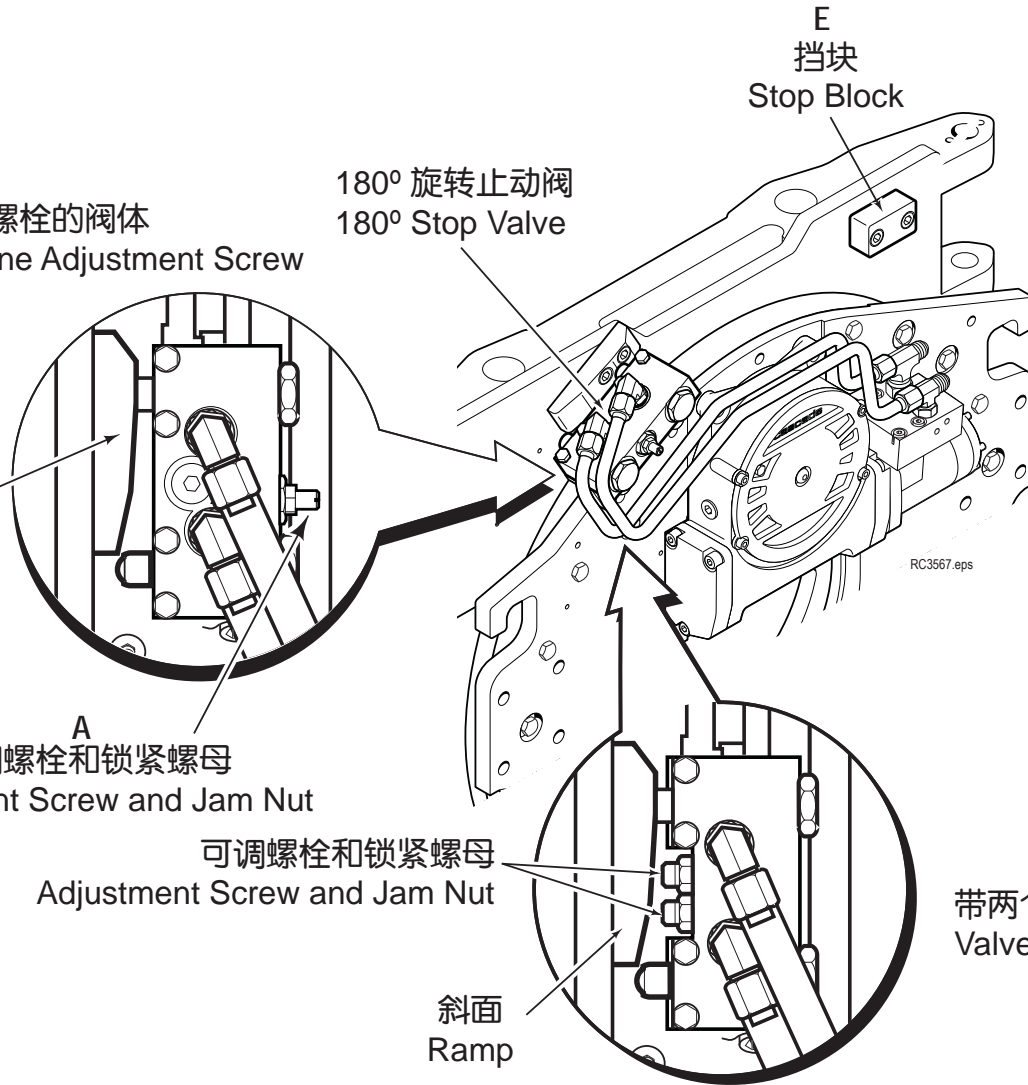

# 安装 / INSTALLATION

## 11

### 循环测试纸卷夹各功能

- 空载时，将所有的功能循环测试数次。
- 依据ISO标准对各功能进行检验。
- 加上一个最大值的负载，进行夹紧和旋转测试，以检验动作的流畅性以及正常的旋转功能。
- 检验接头和活塞杆端是否有外泄漏。

### Cycle Clamp functions

- With no load, cycle all functions several times.
- Check functions for operation in accordance with ANSI (ISO) standards.
- Clamp and rotate a maximum load, check for smoothness and normal rotation.
- Check for leaks at fittings and cylinder rod ends.



**警告：**在测试期间，确保所有的人员对纸卷夹的功能都很熟悉。

**WARNING:** Make sure all personnel are clear of Clamp during testing.

#### 长臂

(仅在水平和垂直方向动作)

C 张开

D 夹紧

#### LONG ARM

(vertical & horizontal positions only)

C Release

D Clamp

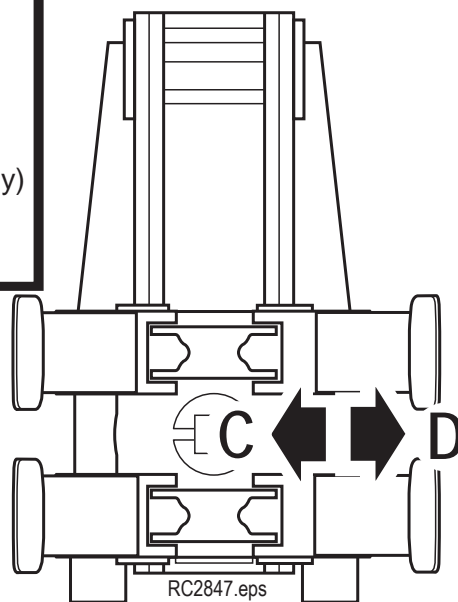

#### 旋转

(从驾驶员方向看)

A 顺时针

B 逆时针

#### ROTATE

(Driver's view)

A Counterclockwise (CCW)

B Clockwise (CW)

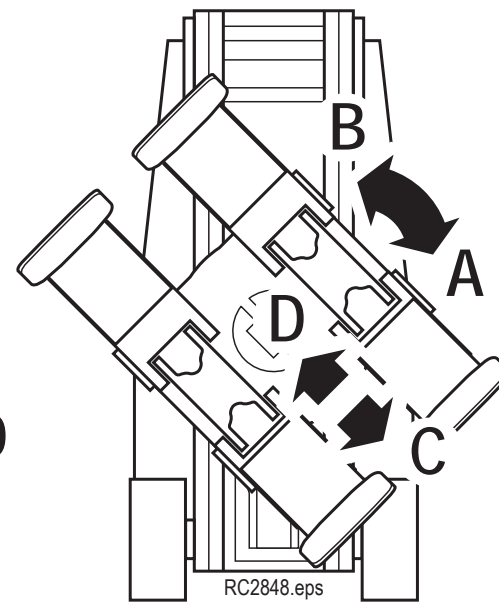

#### 短臂

(仅在两45度角方向动作)

C 张开

D 夹紧

#### SHORT ARM

(45-degree position only)

C Open

D Close

# 安装

# INSTALLATION

## 11

### 多路阀功能 Auxiliary Valve Functions

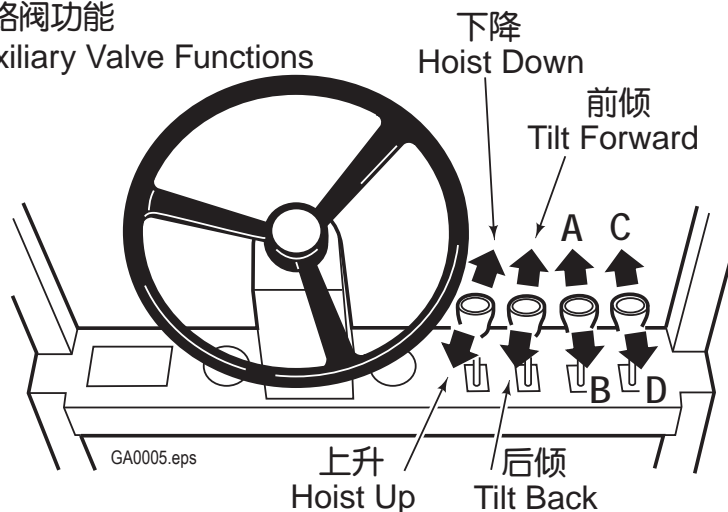

**警告：** 叉车手柄和属具功能的操作均符合美国机械工程协会ASME/美国国家标准协会ANSI B56.1推荐的操作规范。违反该规范要求将会对身体造成严重的伤害或造成财产损失。最终用户，代理商或主机厂需从相关规范中了解违规行为以便进行安全操作。



**WARNING:** Truck control handle and attachment function activation shown here conforms to ASME/ANSI B56.1 recommended practices. Failure to follow these practices may lead to serious bodily injury or property damage. End user, dealer and OEMs should review any deviation from the practices for safe operation.

以下的识别标签（贴在基板上）显示分离夹臂式纸卷夹有何功能（当纸卷夹仅夹持一个纸卷时）：

The following identification decal (located on the baseplate), shows how the split-arm roll clamp functions (when clamping one roll only):

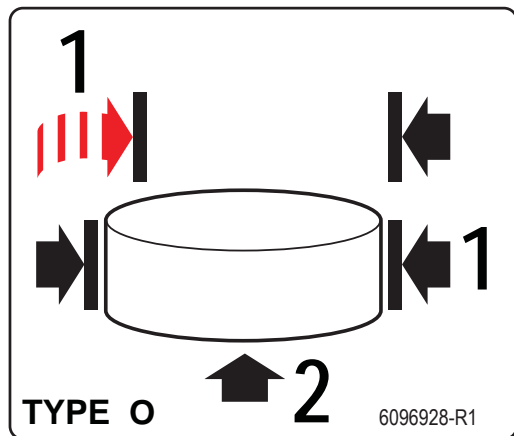

OR

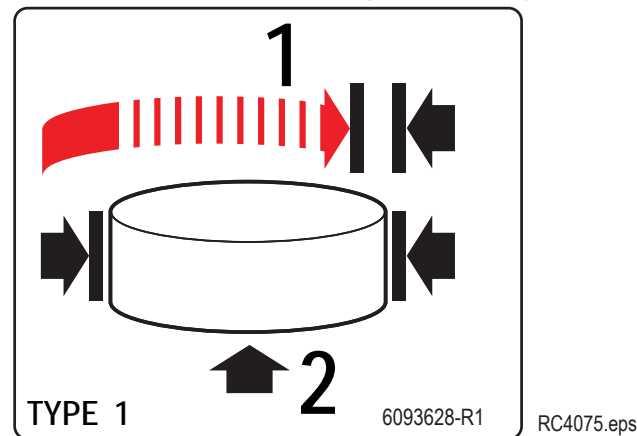

卡斯卡特分离夹臂式纸卷夹，其上方的小夹臂无需夹紧到极限位置便可确保足够的夹持力

Clamp force is developed without the need for the top arm to fully close.

其它同类产品，上方的小夹臂需充分夹紧到位，才可确保足够的夹持力

The top arm must fully close before clamp pressure is developed.

卡斯卡特（厦门）叉车属具有限公司

Cascade Xiamen Forklift Truck Attachment Co.Ltd

地址：厦门市海沧区阳光路668号 邮编：361026

No. 668 Yangguang Road, Haicang, Xiamen, Fujian, 361026 P.R China

电话/Tel: 0592-6512500 传真/Fax: 0592-6512571

**cascade corporation**

**[www.cascorp.com.cn](http://www.cascorp.com.cn)**

卡斯卡特（厦门）公司保留对本手册修改的权利，如有修改，恕不另行通知。

Cascade Xiamen reserves the rights to make change without notice.

1210962 R2 XM CN 6/2015



